

# New calibration and datalogging systems

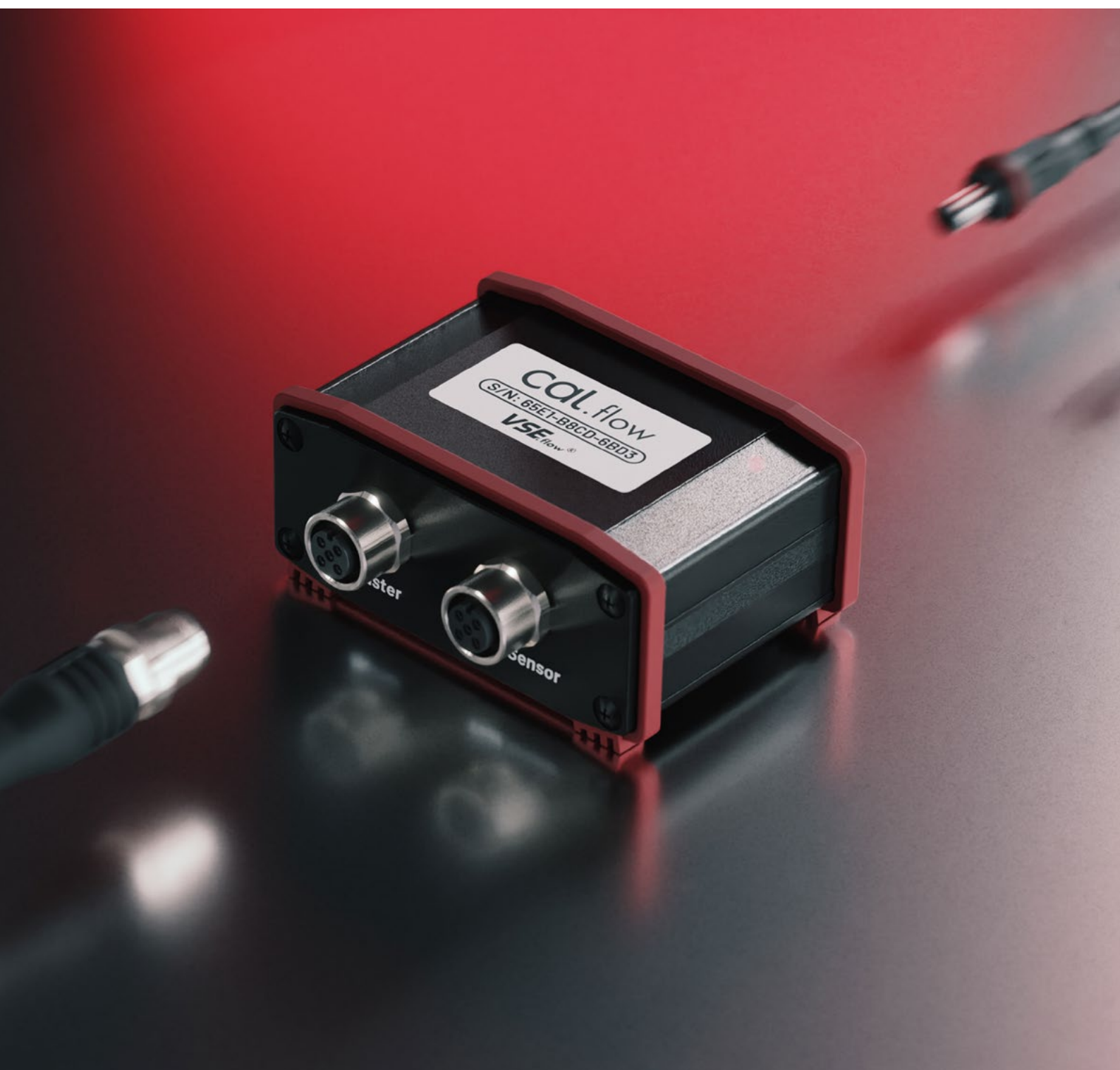



## Flow calibration

### cal.flow + EASYcal

The Cal.flow calibration system is used in conjunction with the EasyCal software to perform flowmeter calibrations with high precision. The process is guided through the PC software and results in a PDF calibration protocol with all measured values.

#### Highlights

- Calibration using master and test flowmeter using the reference principle with up to 24 master calibration points
- Measurement of the K-factor over an adjustable number of pulses
- Highly accurate frequency measurement and counting of both flowmeters
- Automatic calculation of accuracy and repeatability
- Customizable testing procedure
- Export as PDF or Excel-Spreadsheet
- Perfect for manually operated testbenches
- Real-time flowrate graphs

## Data logging

### log.flow + EASYgraph

Log.flow can be used as an excellent data logging tool. Using the PC Software EasyGraph, highly dynamic processes can be analyzed with sampling rates up to 1000 Hz. The flow rate and volume of both channels can be recorded simultaneously.

#### Highlights

- Dynamic and precise frequency measurement and pulse counter (adaptive period measurement)
- GPU-accelerated real-time graph of all 4 channels
- Adjustable sample rate (1-1000 Hz) and filter levels
- Math functionality to rescale input values (→units)
- Data recording with starting-trigger functionality
- Import/Export of recorded data with file viewer
- Fast creation of PDF reports for documentation
- Log.flow versions with a dedicated analog input channel (4..20 mA/0..10 V) are available on request

# A versatile tool for flow measurement

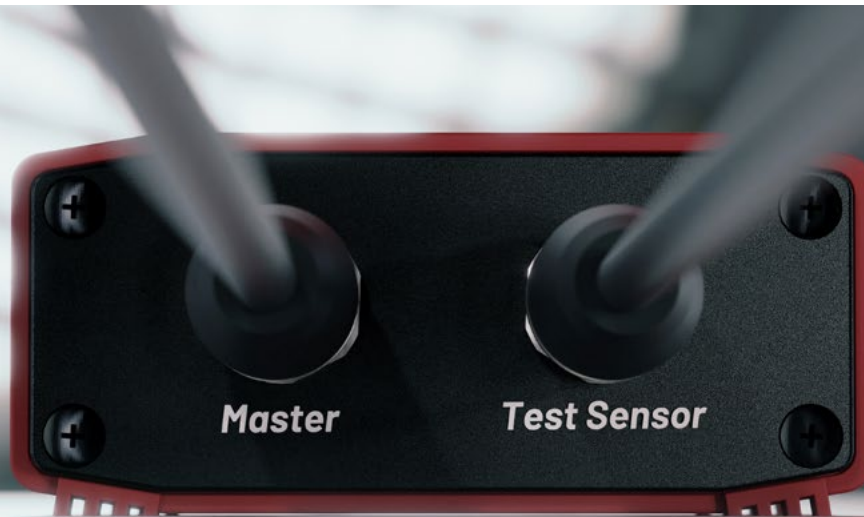

## Product features

- Two new products:
  - Calibration system Cal.flow (Art. no.: 4880)
  - Datalogging system Log.flow (Art. no.: 4881)
- Portable, small size and easy to handle
- Waterproof design for robustness in the field
- Several power supply options possible:
  - Power via USB using integrated boost converter
  - External 24 V power supply using DC-Jack
  - Use of the existing 24 V supply of the connected flowmeters (e.g. by using T-Adapters)

## Scope of delivery

- USB measurement system
- 2x M12 connection cables (length: 1.5 m)
- 2x T-connectors for tapping on flowmeters in existing systems
- 1x USB Type-A to Type-C cable (length: 2 m)
- 24 V DC wall plug power supply with DC Jack
- Download link and device license for companion software (EasyCal or EasyGraph)

### M12 Pinout

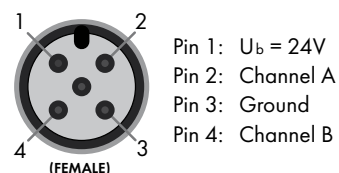

## Technical drawing

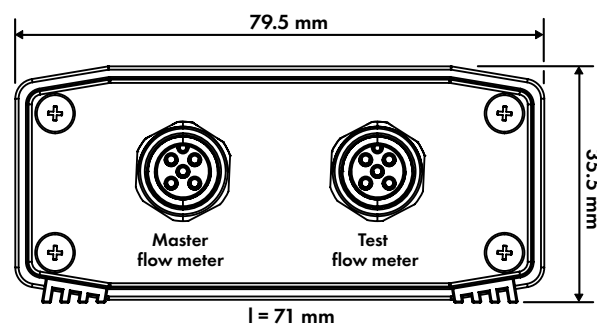
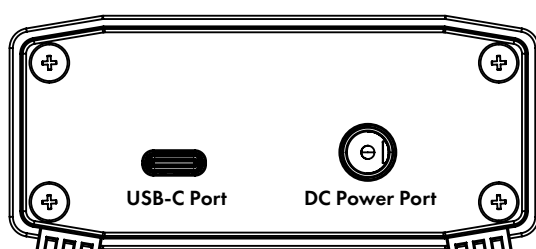

# Flow calibration using EasyCal

from start to finish in 4 easy steps

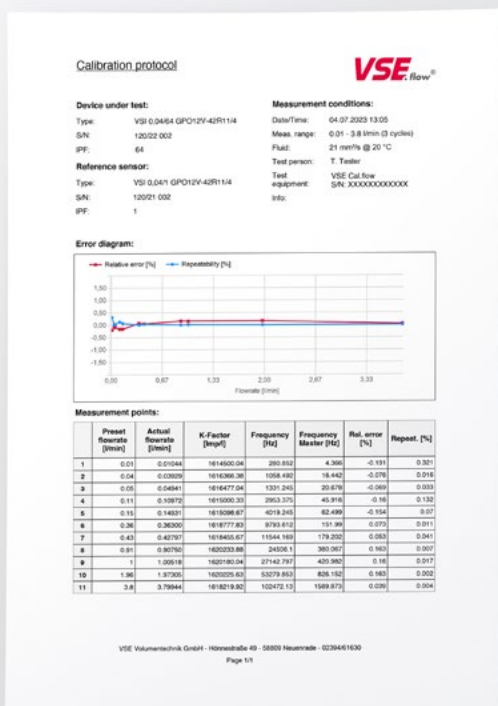
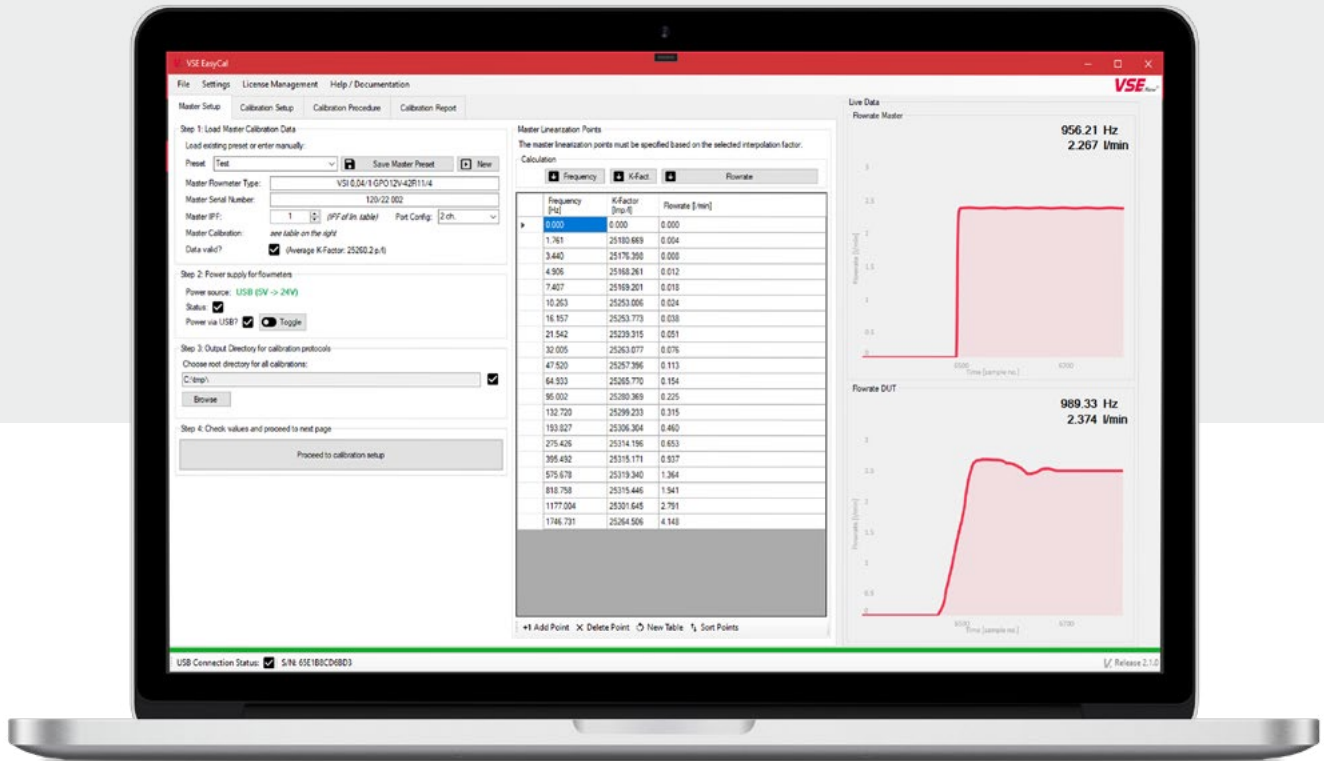

Resulting calibration protocol

## The reference principle

Calibrations with the Cal.flow are performed using the reference principle. This means that an adjustable flow rate is passed in series through a calibrated master flowmeter and through the test device. The Cal.flow records the deviations between the two flowmeters for calculation of the specific K-factor of the test device.

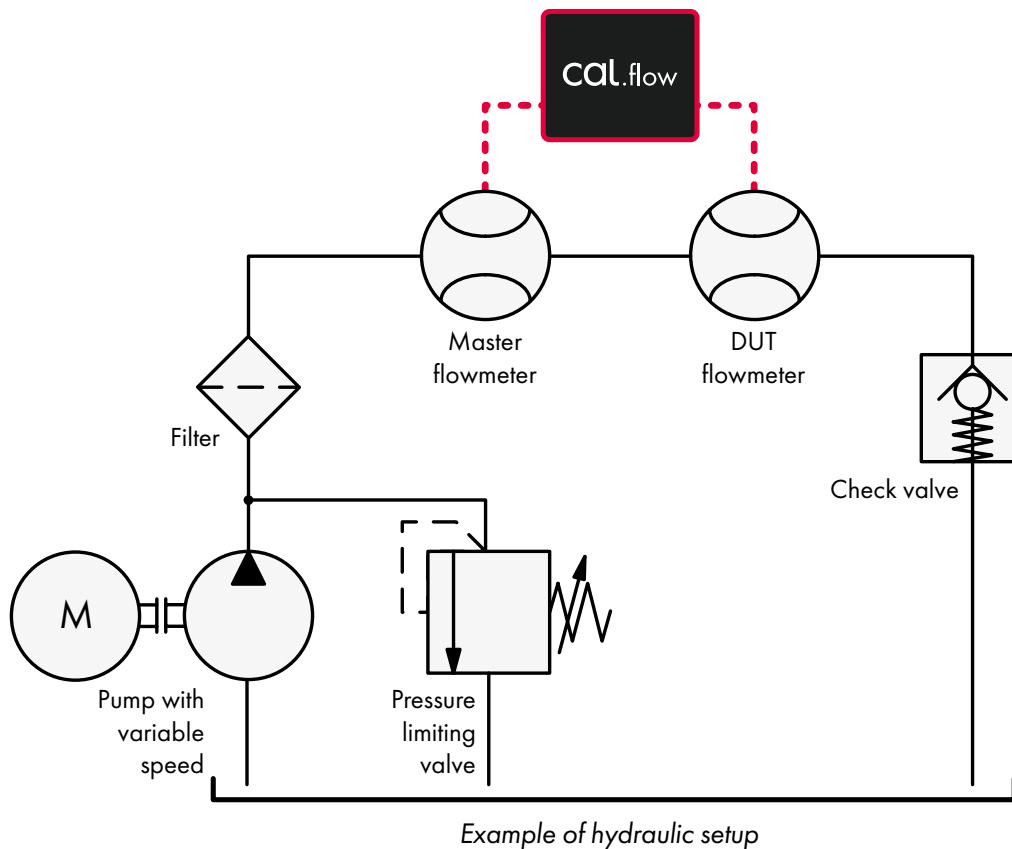

## Additional features of the new system

- Fully customizable calibration parameters
- Adjustable number of reference pulses (= calibration volume)
- Flow hysteresis for steadyness check
- Assisted and manual calibration point calculation
- Optional time limit
- Up to 24 master calibration points
- Save and restore different masters/settings/fluids as presets
- Directly generate fully-featured calibration protocols
- Customize company data (e.g. logo and address) on the protocol

## Comparison to previous version "VSE calibration box"

- Greatly improved measurement accuracy and resolution (compared to pulse comparison method)
- Elimination of measurement errors at the beginning and end of pulse counting
- Use of the more precise ratio-counting method based on a 100 MHz reference clock

# Datalogging with EasyGraph v2.0

Easy-to-use measurement app compatible with the new Log.flow datalogging system



## Understanding the flow

Did you ever wonder what is actually happening inside your fluid system? Do you have flow and pressure spikes that you want to analyze in detail?

Together with VSE's highly dynamic gear- and screw-type flowmeters, those fast flow phenomena can be easily detected and measured. Just use the included T-connectors to tap into your flowmeters to view and record the whole process.



T-connector M12

# Features and highlights

## Key features

- Simultaneous flow and volume measurement
- Two channel measurement:
  - two quadrature inputsor
  - one quadrature input
  - one analog input
- Data recording with trigger functionality (Buffered recording: "before-it-even-happened")
- Highly dynamic and long-term measurements possible

## Hardware specifications

- Three hardware options:
  - Standard-Version: Log.flow (Art. no.: 4881):  
2x Frequency/Counter input
  - Voltage-Option: Log.flow V (Art. no.: 4881/V):  
1x Frequency + 1x 0..10 V input
  - Current-Option: Log.flow I (Art. no.: 4881/I):  
1x Frequency + 1x 0..20 mA input
- Maximum recommended input frequency: 250 kHz
- Maximum sample rate: 1000 Hz
- Measurement accuracy:  $\leq 0.005\%$

## Minimum system requirements

- 2 GHz dual-core processor (x64) or faster
- 64-bit Windows installation
- 4 GB RAM or more
- Graphics card or iGPU with DirectX11 support
- 200 MB free hard disk space
- Screen resolution: at least 1440x900 px
- USB 2.0 interface

## Supported devices

- Log.flow datalogging system (recommended)
- Selected displays and F/U-converters sold by VSE

**VSE**.flow®

VSE Volumenteknik GmbH  
Hönnestraße 49  
58809 Neuenrade / Germany  
Phone +49 (0) 23 94 / 616-30  
info@vse-flow.com  
www.vse-flow.com



A company of  
**e.holding**  
FLUID TECHNOLOGY GROUP

02/24 www.plakart.de