

Solutions for Fluid Technology



OPERATING AND MOUNTING INSTRUCTION

Softex®

TABLE OF CONTENTS

	page
1. Functional description	3
2. Technical data	3
3. Indications	5
3.1 General indications	5
3.2 Warning and indication signs	5
3.3 Indications of risks	5
3.4 Usage	6
4. Storage	6
5. Disposal	6
6. Mounting	6
6.1 Mounting of coupling	6
6.2 Changes of coupling	7
6.3 Mounting	7
6.4 Values of misalignment	8
7. Use in hazardous locations	9
7.1 Indications	9
7.2 Controlling intervals	9
7.3 Wear ratings	10
7.4 Identification	10
7.5 Commissioning	10
7.6 Trouble in service/causes and clearance	11
EU-Certificate of conformity ATEX	13

The current publication of this operating instruction supersedes all information from previous publications. HBE reserves the right to make changes and substitutions. HBE is not liable for any printing errors. Reproduction, including excerpts, is permitted only after written approval by HBE. HBE reserves the right to modify technical data at any time.
Last revised: 10/2021

1. FUNCTIONAL DESCRIPTION

The Softex® coupling is a torsionally flexible, puncture-proof three part claw coupling.

Due to the elastic gear ring, it enables to dampen impacts, torsional vibrations, as well as noises.

Furthermore, the gear ring has a high resistance, elasticity as well as good resistance to oils, greases, a variety of solvents, ozone and influences of the weather.

Due to the construction of the coupling (hub/elastic gear ring/hub), an angular resp. a radial misalignment of the shafts to be connected as well as expansions will be compensated.

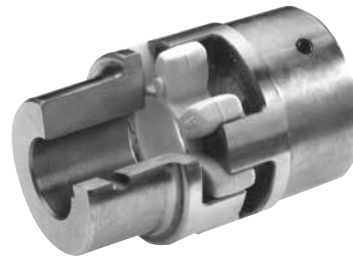

The operating temperatures are between -50°C and $+120^{\circ}\text{C}$, depending on the type of gear ring. Short term temperature peaks up to $+150^{\circ}\text{C}$ are admissible.

2. TECHNICAL DATA

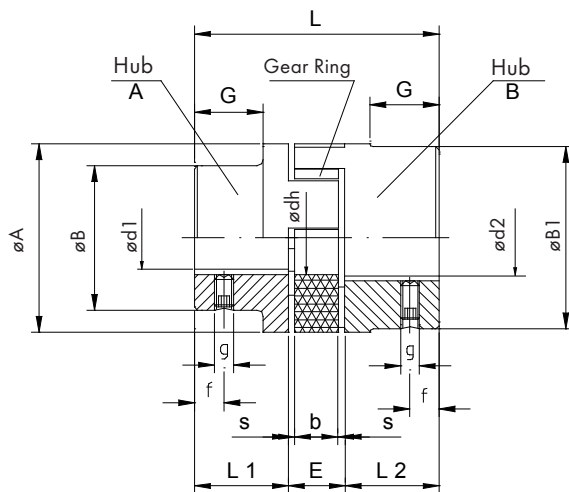

Type:
Clamping Hub (for splines)

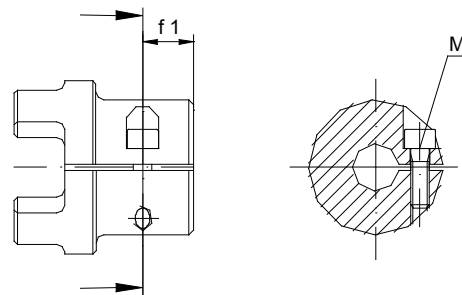

MATERIALS

Aluminium (Al)

Cast Iron (GG)

Spheroidal Cast Iron (GGG)

Steel (St)

Stainless Steel (VA)

Sinter Steel (S)

Type	Hardnesses of gear ring			Bores [mm]				Dimensions [mm]													
	Nominal torque [Nm]			Finish bore d 1		Finish bore d 2		A	B	B ₁	L	L ₁ + L ₂	E	s	b	G	dh	g	f	f1	M
	92 Sh A	98 Sh A	64 Sh D	min	max	min	max														
14/16	7.5	12.5		-	-	4	16	30	-	-	35	11	13	1.5	10	-	10	M4	5	5	M3
19/24	10	17	-	-	-	6	24	40	-	-	66	25	16	2	12	-	18	M5	10	12	M6
24/30	35	60	75	-	-	8	32	55	-	-	78	30	18	2	14	-	27	M5	10	14	M8
28/38	95	160	200	-	-	10	38	65	-	-	90	35	20	2.5	15	-	30	M6	15	15	M8
38/45	190	325	405	14	38	40	45	80	66	78	114	45	24	3	18	37	38	M8	15	20	M10
42/55	265	450	560	16	42	45	55	95	75	93	126	50	26	3	20	40	46	M8	20	20	M10
48/60	310	525	655	19	48	50	60	105	85	103	140	56	28	3.5	21	45	51	M8	20	30	M10
55/70	410	685	750	22	55	60	70	120	98	118	160	65	30	4	22	52	60	M10	20	25	M12
65/75	625	940	800	25	65	70	75	135	115	132	185	75	35	4.5	26	59	68	M10	20	30	M12
75/90	1280	1920	1830	30	75	80	90	160	135	158	210	85	40	5	30	65	80	M10	25	30	M16
90/100	2400	3600	4500	-	-	45	100	200	-	170	245	100	45	5.5	34	81	100	M10	25	30	M20
100/110	3300	4950	-	-	-	45	110	225	-	180	270	110	50	6	38	89	113	M12	30	-	-
110/125	4000	7200	-	-	-	60	125	255	-	200	295	120	55	6.5	42	96	127	M16	35	-	-
125/145	5000	7500	-	-	-	60	145	290	-	230	340	140	60	7	46	112	147	M16	40	-	-

FLANGE HUB

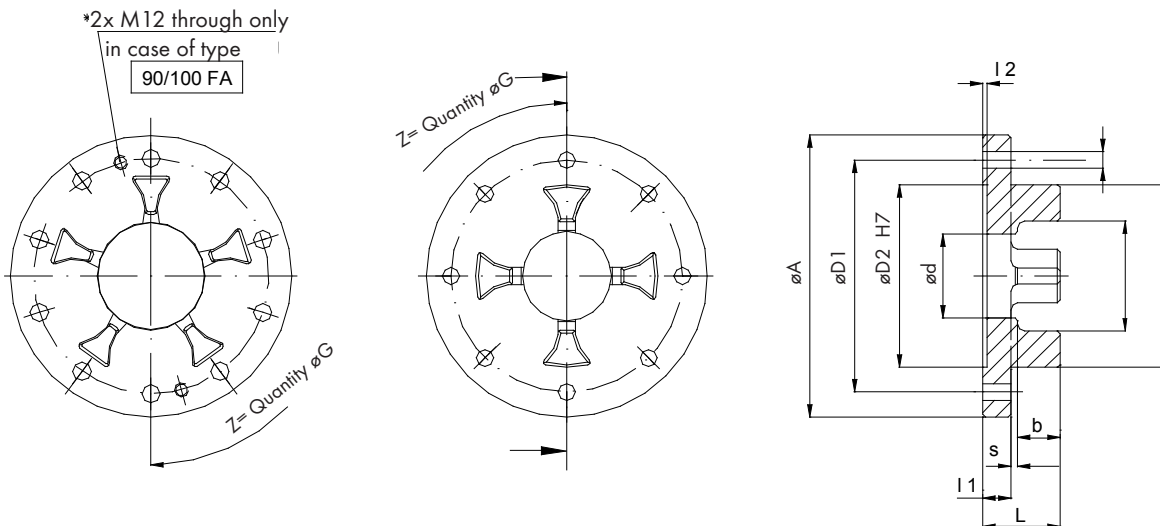

Types 75/90 - 90/100 FA

Types 28/ 38 - 65/75 FA

Type	Dimensions [mm]												
	A	A ₁	L	L ₁	s	b	F	I ₂	D ₁	D ₂	d	G	Z
24/30 FA	80	55	24	8	1	15	35	1,5	65	55	27	4,5	5
28/38 FA	100	65	27.5	10	2.5	15	39	1.5	80	65	30	7	6
38/45 FA	115	80	31	10	3	18	48	1.5	95	80	38	7	6
42/55 FA	140	95	35	12	3	20	57	2	115	95	46	9	6
48/60 FA	150	105	36.5	12	3.5	21	63	2	125	105	51	9	8
55/70 FA	175	120	42	16	4	22	74	2	145	120	60	11	8
65/75 FA	190	135	46.5	16	4.5	26	83	2	160	135	68	11	10
75/90 FA	215	160	54	19	5	30	98	2.5	185	160	80	14	10
90/100 FA	260	200	59.5	20	5.5	34	122	3	225	200	100	14	12
100/110 FA	285	225	69	25	6	38	137	4	250	225	113	14	12

Tightening torque for the fixing screws
DIN 912 - 10.9

Thread	M6	M8	M10	M12
Torque [Nm]	14	35	69	120

3. INDICATIONS

3.1 GENERAL INDICATIONS

Before initial operation, the installation instructions must be read carefully. Please pay attention to the security and warning indications. The Softex® coupling is approved for application in hazardous areas.

Please pay special attention to the indications and prescriptions concerning security (Item 6). This operating and mounting instruction is part of the delivery extent and must be kept carefully.

3.2 WARNING AND INDICATION SIGNS

Passages with following indications must be especially paid attention to.

DANGER ! Danger of injury for persons
ATTENTION! Engine trouble possible
INDICATION! Important items
CAUTION! Indications to protection in hazardous areas

3.3 INDICATIONS OF RISKS

DANGER!

Due to the high risk of injury by rotating parts, you must ensure that the complete system is protected from accidental activation during mounting, service and maintenance. Please imperatively pay attention to the following safety information:

- During all activities with and at the coupling, please especially pay attention to the safety regulations.
- Before starting the activities at the coupling, the power unit must be switched off.
- The power unit must be protected from unintentional switching on by labels or removing of the protector.
- The unintentional contact of a running coupling must be prevented by appropriate safety devices.
- In case of operating couplings please pay attention to a sufficient safety clearance.

3.4 USAGE

The following items must be paid attention to before mounting, operation or service of the coupling.

- The operating and mounting instructions are to be read imperatively.
- Operations must only be made by qualified personnel.

4. STORAGE

Due to the corrosion protection which must not be damaged, the coupling can be stored for approx. 6 - 12 months at a dry place.

The gear rings (Polyurethane) keep their qualities in case of a corresponding storage for approx. 5 years.

5. DISPOSAL

The disposal of packaging or of the product at the end of its operating life must be carried out in compliance with legal regulations and guidelines.

6. MOUNTING

6.1 MOUNTING OF COUPLING

Basically, the coupling is supplied in component parts. Before mounting, the coupling must be checked for completeness.

Item	Pieces	Denomination
1	2	Hub
2	1	Gear Ring
3	2	Set screw or Cheese head screw

Distinguishing features of the gear rings (Item 2)

Shore hardness (shore)	Marking (colour)
80 Sh A	blue
92 Sh A	white
98 Sh A	red
64 Sh D	green

The coupling must only be applied in accordance to its corresponding technical data. Constructional changes of the coupling parts without any permission by the manufacturer are illegal and result in loss of warranty.

ATTENTION!

It must be ensured that there is no condensation in the storage rooms. A relative humidity of less than 65 % is favourable.

Furhtermore, please ensure that there are no ozone generating devices, such as illuminants or high voltage devices in the storage rooms.

The materials must be disposed of properly as follows:

- Metal
- Plastics
- Sealings (residual waste)
- etc.

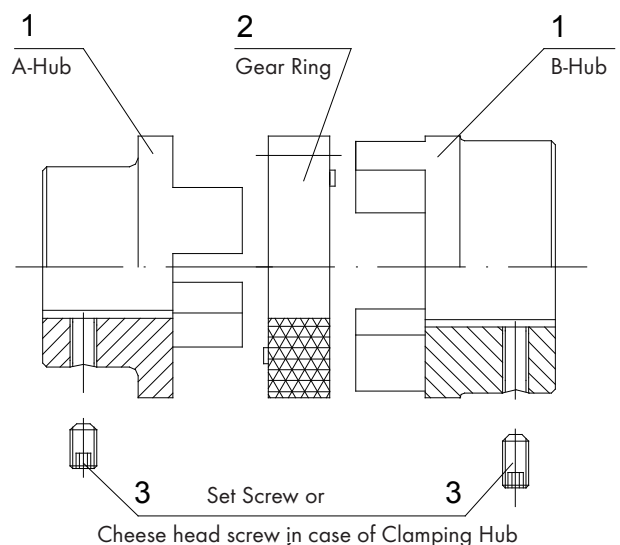

6.2 CHANGES OF COUPLING

DANGER!

A change at the coupling parts is only permitted after having checked with the manufacturer.

For making the shaft bore by the user, please pay attention to the following items:

- The maximum admissible bore diameter $d_1 + d_2$ (see Technical Data) must not be exceeded. In case of disregard of these values, the coupling might break. Flying fragments can cause serious personal injuries. This concerns all materials.

- The predetermined planning and rotation accuracy of the manufacturer must be adhered to.
- For making the finish bore, a careful alignment must be made.
- For the axial safety device, please use a locking screw.
- If using a locking screw, following tightening torques must be kept (see table):

Tightening torques of the locking screws

Type	14	19	24	28	38	42	48	55	65	75	90	100	110	125
Thread	M4	M5	M5	M6	M8	M8	M8	M10	M10	M10	M10	M12	M16	M16
Torque [Nm]	1.5	2	2	4,8	10	10	10	17	17	17	17	40	80	80

Tightening Torques of the locking screws for clamping hubs

Type	14	19	24	28	38	42	48	55	65	75	90
Thread	M3	M6	M8	M8	M10	M10	M10	M12	M12	M16	M20
Torque [Nm]	1.34	10.5	25	25	60	60	60	100	100	250	490

6.3 MOUNTING

INDICATION!

Before mounting, we recommend to check the bores, shaft, hub and feather key for accuracy.

A heating of the hubs to approx. 80°C eases the fitting onto the shaft.

DANGER!

In order to avoid burnings by the contact with ted hubs, please wear safety gloves.

CAUTION!

Please pay attention to the danger of ignition in hazardous areas.

ATTENTION!

When mounting the coupling, please ensure that the dimension E (see Technical Data) must absolutely be kept, so that the gear ring is axially movable during operation. Disregard might lead to damages.

- After mounting of the hubs to the shafts of the drive and load side, the dimension "E" must be adjusted by relocation of the aggregates or the hubs on the shafts.
- Shafts with inserted feather key and a smaller diameter than the inner diameter of the gear ring d_h may reach into the gear ring. The distance between the shafts must not be lower than 50% of the dimension "E".
- For securing the hubs by relocation, please tighten the locking screw with corresponding starting torque (Table 6.3).

6.4 VALUES OF MISALIGNMENT

CAUTION!

During operation in hazardous areas, the ends of the shaft must imperatively be aligned. Furthermore, the durability of the coupling can be increased by an exact alignment. Please keep the recommended values of misalignment (see table).

Exceeding of the values will lead to damages on the coupling. For operation in hazardous areas of explosion groups IIC (Designation II 2G c IIC T4), the values must be reduced by 50%.

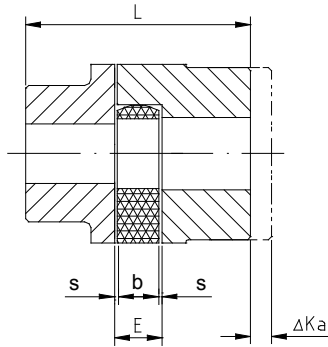

Axial misalignment

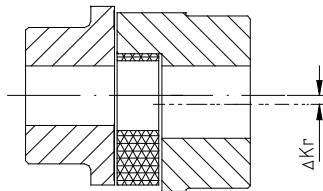

Radial misalignment

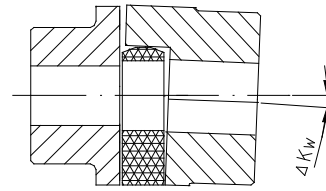

Misalignment of angle

The values of the table are valid for an operating temperature $T = +30^\circ$.

ATTENTION!

In case of an increase of the operating temperature, the maximum permissible values of radial alignment and misalignment of angle must be multiplied by the temperature factor.

Type	Dimensions [mm]				Axial misalignment ΔK_a [mm]	Radial misalignment ΔK_r [mm]				Misalignment of angle ΔK_w [°]			
	L	E	b	s		Speed n [1/min]				Speed n [1/min]			
						750	1000	1500	3000	750	1000	1500	3000
14/16	35	13	10	1.5	1.0	0.22	0.20	0.16	0.11	1.1	1.1	0.9	0.8
19/24	66	16	12	2.0	1.2	0.27	0.24	0.20	0.13	1.1	1.1	0.9	0.8
24/30	78	18	14	2.0	1.4	0.30	0.27	0.22	0.15	1.1	1.0	0.9	0.8
28/38	90	20	15	2.5	1.5	0.34	0.30	0.25	0.17	1.1	1.0	0.9	0.8
38/45	114	24	18	3.0	1.8	0.38	0.35	0.28	0.19	1.1	1.1	1.0	0.8
42/55	126	26	20	3.0	2.0	0.43	0.38	0.32	0.21	1.1	1.1	1.0	0.8
48/60	140	28	21	3.5	2.1	0.50	0.44	0.36	0.25	1.2	1.2	1.1	0.9
55/70	160	30	22	4.0	2.2	0.54	0.46	0.38	0.26	1.2	1.2	1.1	1.0
65/75	185	35	26	4.5	2.6	0.56	0.50	0.42	0.28	1.2	1.2	1.2	1.0
75/90	210	40	30	5.0	3.0	0.65	0.58	0.48	0.32	1.3	1.2	1.2	1.0
90/100	245	45	34	5.5	3.4	0.68	0.60	0.50	0.34	1.3	1.3	1.2	1.1
100/110	270	50	38	6.0	3.8	0.71	0.64	0.52	0.36	1.3	1.3	1.2	1.1
110/125	295	55	42	6.5	4.2	0.75	0.67	0.55	0.38	1.3	1.3	1.3	1.1
125/145	340	60	46	7.0	4.6	0.80	0.70	0.60	-	1.3	1.3	1.3	-

The maximum admissible values of misalignment mentioned in the table must only be used proportionally in case of parallel radial alignment and alignment of angle.

Example 1:

$$\Delta K_r = 20 \%$$

$$\Delta K_w = 80 \%$$

Example 2:

$$\Delta K_r = 60 \%$$

$$\Delta K_w = 40 \%$$

$$\Delta K_{\text{totally}} = \Delta K_r + \Delta K_w \leq 100 \%$$

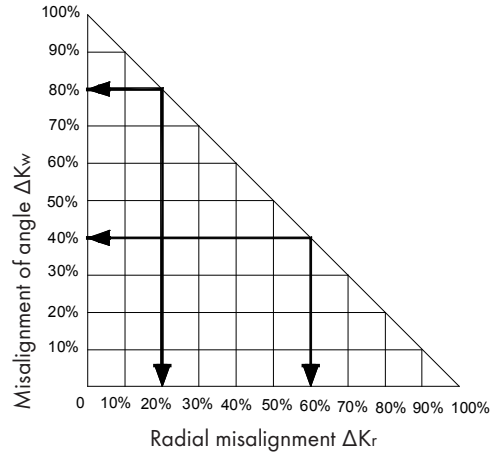

7. USE IN HAZARDOUS LOCATIONS

7.1 INDICATIONS

CAUTION!

Concerning the explosion groups IIB and IIC, following materials are used by HBE:

Cast Iron (GG25, GG20) Stainless Steel (VA)

Spheroidal Cast Iron (GGG40) Sinter Steel (S)

Steel (St)

HBE does NOT use aluminium as material for the couplings applied in hazardous areas.

7.2 CONTROLLING INTERVALS

Explosion group	Controlling intervals
II 2G C IIB T4 X II 2D C T 110°C X I M2 C X	<p>After an operating time of 3000 h, 6 months after initial operation of the coupling at the latest, the elastic gear ring must be put to test (visual check, torsion test).</p> <p>In case of an unessential or no wear of the gear ring during first check, the check cycles can be set to an operating time of 6000 h or 18 months at the same operating conditions.</p> <p>In case of an increased wear at first check, we recommend to proceed as followed:</p> <ul style="list-style-type: none"> • Exchange of the gear ring • Determination of cause • Adjustment of the check cycles to the operating conditions
II 2G C IIC T4 X	<p>After an operating time of 2000 h, 3 months after initial operation of the coupling at the latest, the elastic gear ring must be put to test (visual check, torsion test).</p> <p>In case of an unessential or no wear of the gear ring during first check, the check cycles can be set to an operating time of 4000 h or 12 months at the same operating conditions.</p> <p>In case of an increased wear at first check, we recommend to proceed as followed:</p> <ul style="list-style-type: none"> • Exchange of the gear ring • Determination of cause • Adjustment of the check cycles to the operating conditions

7.3 WEAR RATINGS

The check of the wear limit shall be made by a guide between tooth flank and coupling claw.

In case of a backlash $> X$ mm, the gear ring must be exchanged.

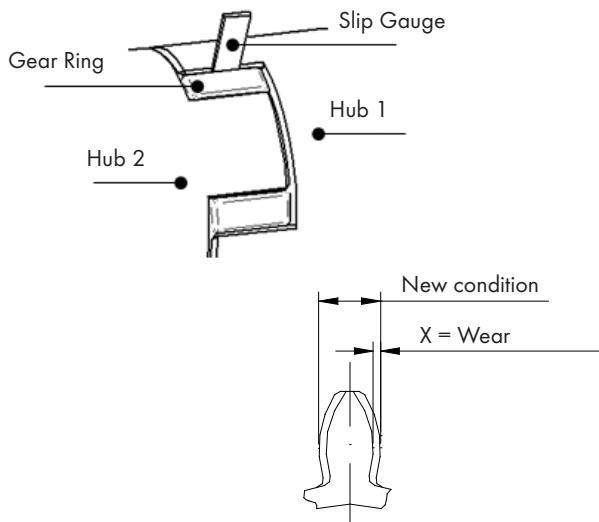

7.4 IDENTIFICATION

Couplings for use in hazardous areas have to be marked respectively for the permitted conditions of use.

Identification mark:

II 2G c IIB T4 X **II 2G c IIC T4 X**
II 2D c T 110°C X **I M2 c X**

7.5 COMMISSIONING

Bevor commissioning of the coupling, following checks and possible corrections must be made:

- Check of alignment
- Check of misalignment
- Check of distance dimension E
- Check of the tightness of the set screws in the hubs
- Check of the tightness of the fixing screws when using flange hubs

Afterwards, the user has to fit a coupling protection consisting of a fixed cover. The cover is intended to protect the coupling especially from falling items. The covers can be provided with regular openings. Following dimensions must not be exceeded.

Type	Wear limit X max. [mm]
14/16	2
19/24	3
24/30	3
28/38	3
38/45	3
42/55	4
48/60	4
55/70	5
65/75	5
75/90	6
90/100	8
100/110	9
110/125	9
125/145	10

The explosion groups **IIB** and **IIA** as well as the temperature ranges **T3 – T1** are included in the identification mark **II 2G c IIC T4 X**.

CAUTION!

In hazardous areas, the set screws fixing the hubs and the fixing screws of the flange hubs must be secured against self-loosening, e.g. glue with Loctite 270.

	Round openings Ø [mm]	Rectangular openings side length [mm]
Top of cover	4	4
Side of cover	8	8

The distance of the cover to rotating parts must be at least 5 mm. The cover must be electrically conductive and must be included in the potential equalisation. The cover is only allowed to be taken off during a halt. Aluminium bellhousings (also with damping flange) are permitted as connecting element, if the content of magnesium is less than 7.5 %.

CAUTION!

When mounting the coupling to machines of category 2D, please ensure that there is no dust between cover and coupling. The couplings must not operate in dust particles. When using the coupling in machines of group I, category M2, the cover must not consist of light metal (higher mechanical load).

During operation of the coupling please pay attention to:

- Changed operation noises
- Occurring vibrations

ATTENTION!

In case of changes or irregularities during the operation of the coupling, the power unit must be switched off immediately. The cause of the disturbance must be found out by the check list "Trouble in service" and be removed, if possible.

7.6 TROUBLE IN SERVICE / CAUSES AND CLEARANCE

A disturbance by break of the fixing screws of the flange couplings must be excluded under observance of the selection criteria.

Disturbances	Causes	Indications of risks for hazardous areas	Clearance
Changes of running noises Vibrations	Alignment fault	High temperatures at the surface lead to an ignition risk	<ul style="list-style-type: none"> • Stop the unit • Check and remove changes in construction • Check the drive unit for damages • Check and correct, if necessary, alignment and dimension E of the coupling • Check the wear of the gear ring and exchange, if necessary
	Loose screws for axial securing of the hub	Ignition risk by hot surface and sparking	<ul style="list-style-type: none"> • Stop the unit • Check and correct alignment and dimension E of the coupling • Check the wear of the gear ring and exchange, if necessary • Retighten the fixing screws by the starting torque and protect it from self-loosening with Loctite
Changes of running noises Vibrations	Wear of gear ring Short-term torque transfer by metal contact	Ignition risk by sparking	<ul style="list-style-type: none"> • Stop the unit • Dismount the coupling • Remove the gear ring • Check the parts of the coupling and exchange damaged parts • Renew the gear ring • Check and, if necessary, correct the alignment • Tighten the fixing screws with tightening torque and protect it from self-loosening with Loctite

Disturbances	Causes	Indications of risks for hazardous areas	Clearance
Break of claw	Blockage and overload rupture of claws by operating errors	Ignition risk by sparking due to metal contact of the claws	<ul style="list-style-type: none"> • Stop the unit • Dismount the coupling • Check the shafts and feather keys for damages • Check the drive unit for damages • Mount the complete coupling • Check the alignment • Tighten the fixing screws with tightening torque and protect it from self-loosening by Loctite
	The parameters for the determination of the coupling do not correspond to the actual operation conditions. Dimensions of coupling too small.		<ul style="list-style-type: none"> • Stop the unit • Dismount the coupling • Check the shafts and feather keys for damages • Check the operating parameter and choose a harder gear ring or bigger coupling • Check the mounting space when deciding for a bigger coupling • Mount the complete coupling • Check and correct, if necessary, alignment and dimension E of the coupling • Tighten the fixing screws with tightening torque and protect it from self-loosening with Loctite
	Increased wear of gear ring Claws smash during torque transfer		<ul style="list-style-type: none"> • Stop the unit • Check the mounting and remove errors of alignment • Check the parts of the coupling and exchange damaged parts • Exchange the gear ring • Check and correct, if necessary, alignment and dimension E of the coupling • Tighten the fixing screws with tightening torque and protect it from self-loosening with Loctite
Premature wear of gear ring	Error of alignment Dimension E was not kept	Ignition risk by high temperatures at the gear ring	<ul style="list-style-type: none"> • Stop the unit • Check the mounting and remove errors of alignment • Check the parts of the coupling and exchange damaged parts • Exchange the gear ring • Check and correct, if necessary, alignment and dimension E of the coupling • Tighten the fixing screws with tightening torque and protect it from self-loosening with Loctite
	Torsional vibrations destroy the charged teeth inside	Ignition risk by sparking during metal contact of the claws	<ul style="list-style-type: none"> • Stop the unit • Check the parts of the coupling and exchange damaged parts • Find out and remove cause of vibration • Exchange the gear ring (eventually choose smaller or higher shore hardness, please pay attention to the size of the coupling) • Check and correct, if necessary, alignment and dimension E of the coupling • Tighten the fixing screws with tightening torque and protect it from self-loosening with Loctite
Premature wear of gear ring	Inadmissibly high temperatures by contact heating	Ignition risk by sparking during metal contact of the claws	<ul style="list-style-type: none"> • Stop the unit • Check the parts of the coupling and exchange damaged parts • Find out and remove the source of heat • Exchange the gear ring • Check and correct, if necessary, alignment and dimension E of the coupling • Tighten the fixing screws with tightening torque and protect it from self-loosening with Loctite
	Aggressive environmental conditions (vapours, chemicals, etc.) and/or liquids (bio oils)		<ul style="list-style-type: none"> • Stop the unit • Check the parts of the coupling and exchange damaged parts • Check and correct the environmental conditions • Check the operating medium and change, if possible • Exchange the gear ring • Check and correct, if necessary, alignment and dimension E of the coupling • Tighten the fixing screws with tightening torque and protect it from self-loosening with Loctite

EU - Certificate of conformity in reference to guidelines 94/9/EG (Atex)

Manufacturer **HBE GmbH
Hönnestraße 47
D-58809 Neuenrade**

Product description **Softex® couplings
Hub design A - Size 38/45 to 90/100
Hub design B - Size 14/16 to 125/145
Flange hubs - Size 28/38 to 90/100**

The sole responsibility to issue this certificate is of the manufacturer.

The safety-relevant instructions and the conditions for the installation of this component in equipments and protective systems are specified in the operating instructions and are to be adhered to, to ensure that the essential health and safety requirements applicable to assembled equipments and protective systems are met in accordance with Annex II to Directive 94/9/EG. HBE GmbH confirms that the above mentioned products are in compliance with the essential health and safety requirements relating to design and construction of products intended for use in potentially explosive atmospheres given in Annex VIII to Directive 94/9/EG of the European Parliament and of the Council, dated 23.03.1994.

**II 2G c IIC T4 X
II 2D c T 110°C X
I M2 c X
-20°C ≤ Ta ≤ +80°C**

The compliance of the above labeled products with the requirements of the EU guidelines is demonstrated by compliance with the following standards:

**DIN EN 1127-1:2017:12
EN 80079-36-2016 , EN 80079-37-2016**

It is confirmed that the technical documentation as set out in Annex VIII of Directive 94/9/EG for the non-electrical component mentioned above is stored at the Notified Body IBExU (EU identification no. 0637) in accordance with the regulations of Directive 94/94/EG, Article 8 (1) b) ii) (Test Report No. IB-04-4-032). "The subject-matter of the certificate described above complies with the relevant union harmonization legislation: Directive 94/9/EC (until 19 April 2016) and Directive 2014/34/EU (from 20 April 2016)".

Neuenrade 09.02.21

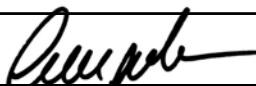
Detlef Längelsen (Managing Director)

HBE hydraulic
components



HBE GmbH
Hönnestraße 47
58809 Neuenrade

Phone +49 (0) 23 94 / 616-0
Fax +49 (0) 23 94 / 616-25
info@hbe-hydraulics.com
www.hbe-hydraulics.com

e.holding
FLUID TECHNOLOGY GROUP
www.e-holding.de