

# Partial flow cooler ACIP

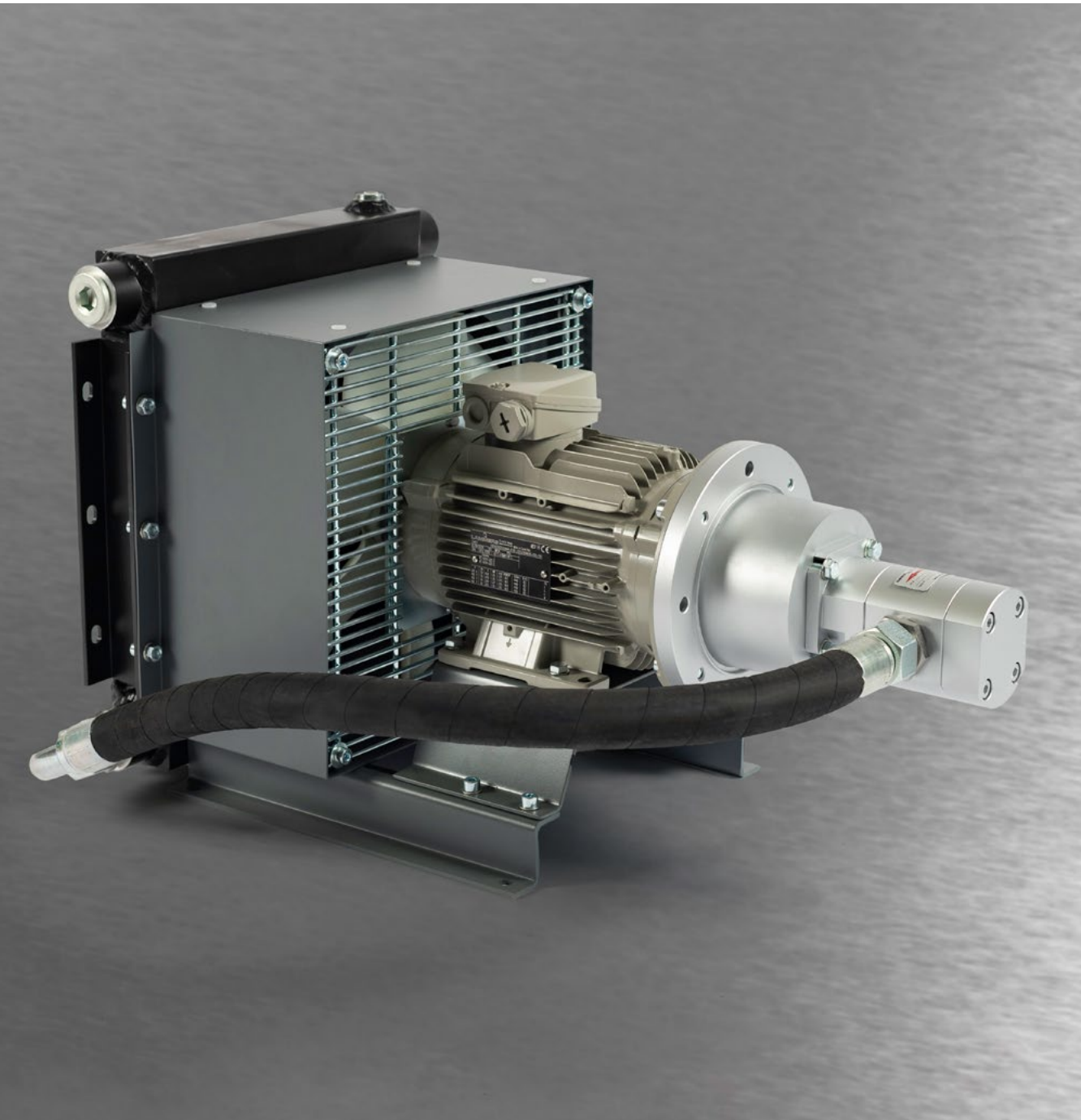

## Partial flow cooler unit for industrial use



## SERIES ACIP

The new cooler system ACIP is optimised for a wide range of hydraulic applications. An integrated motor pump unit makes it possible to cool the oil efficiently and continuously in a separate circuit. The cooling process is working independently from the operation condition of the main hydraulic power unit.

### Product features

- Oil-air cooler ACI with motor & pump in one unit
  - Drive motor 230/400 V, 50 Hz, 1450 min<sup>-1</sup>
  - Gear pump, operating pressure: 4 bar
  - Bellhousing and coupling
- Continuous cooling process
- Permissible viscosity range: 10 - 300 mm<sup>2</sup>/s
- Max. operating temperature 90°C
- Max. suction height 1 m

### Benefits

- Easy to retrofit in existing systems
- Extension of oil life due to permanent cooling
- Extended service life of seals and hydraulic components
- High flexibility in the choice of the pump
- Short delivery times by intelligent warehousing

## Ordering code

ACIP - 11 - 19 - 1,1 - 4 - 01	
<b>Cooler series</b> ACIP = Partial flow cooler	<b>Series</b> 00 = Without pump / without hose** 01 = External gear
<b>Cooler size</b> 11 21 31 41 51 61	<b>Fan speed</b> 4 = 4 pole / 1500 min <sup>-1</sup> 6 = 6 pole / 1000 min <sup>-1</sup>
<b>Displacement*</b> 19 = 19 cm <sup>3</sup> 32 = 32 cm <sup>3</sup> 50 = 50 cm <sup>3</sup>	<b>Power</b> 1,1 = 1.1 kW 1,5 = 1.5 kW 2,2 = 2.2 kW

\* additional on request \*\* Option for customer to install a compatible own pump, attention: new selection of bellhousing and coupling required

The current publication of this catalogue supersedes all information from previous publications. HBE reserves the right to make changes and substitutions. HBE is not liable for any printing errors. Reproduction, including excerpts, is permitted only after written approval by HBE.  
Last revised: 08/2023

## Dimensions

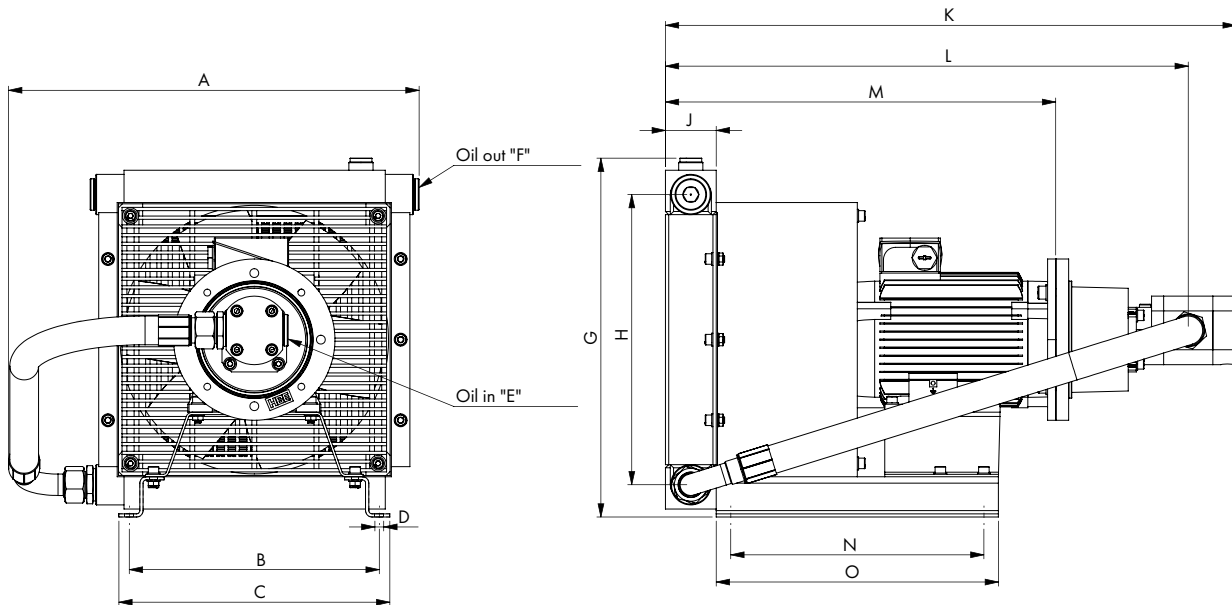

Cooler size	A	B	C	D	E	F	G	H	J	K	L	M	N	O		
ACIP-11-19-1,1-4	510	310	336	Ø 11	G1"	G1"	445	360	63	711	652	487	314	350		
ACIP-11-32-1,5-4									735	647	507					
ACIP-21-19-1,1-4									94	742	683	518				
ACIP-21-32-1,5-4									94	766	678	538				
ACIP-31-19-1,1-4	590	450	476				G1"	G1 1/2"	565	460	63	741			682	517
ACIP-31-32-1,5-4											63	765			677	537
ACIP-41-19-1,1-4											94	772			713	548
ACIP-41-32-1,5-4											94	796			708	568
ACIP-51-32-2,2-4	675	620	646		G1"	G1 1/2"	726	610	63	859	810	621				
ACIP-51-50-2,2-4					63				883	822	621					
ACIP-61-32-2,2-4					94				890	841	652					
ACIP-61-50-2,2-4					94				914	853	652					

## Technical data

Cooler size	Oil flow		Cooling capacity		Power	Electricity	Weight
	[cc/rev]	[l/min]	[kW/K]	[kW (ΔT = 40K)]	[kW]	[A]	[kg]
ACIP-11-19-1,1-4	19	27	0.16	6	1.1	2.5	37
ACIP-11-32-1,5-4	32	45	0.17	7	1.5	3.3	42
ACIP-21-19-1,1-4	19	27	0.20	8	1.1	2.5	40
ACIP-21-32-1,5-4	32	45	0.22	9	1.5	3.3	45
ACIP-31-19-1,1-4	19	27	0.37	15	1.1	2.5	46
ACIP-31-32-1,5-4	32	45	0.40	16	1.5	3.3	51
ACIP-41-19-1,1-4	19	27	0.42	17	1.1	2.5	52
ACIP-41-32-1,5-4	32	45	0.46	18	1.5	3.3	57
ACIP-51-32-2,2-4	32	45	0.69	28	2.2	4.5	89
ACIP-51-50-2,2-4	50	70	0.77	31	2.2	4.5	90
ACIP-61-32-2,2-4	32	45	0.80	32	2.2	4.5	98
ACIP-61-50-2,2-4	50	70	0.90	36	2.2	4.5	99

Explore our  
product diversity



[epaper.hbe-hydraulics.com](http://epaper.hbe-hydraulics.com)

**HBE** hydraulic  
components

HBE GmbH  
Hönnestraße 47  
58809 Neuenrade / Germany  
Phone +49 (0) 23 94 / 616-0  
[info@hbe-hydraulics.com](mailto:info@hbe-hydraulics.com)  
[www.hbe-hydraulics.com](http://www.hbe-hydraulics.com)



A company of  
**e.holding**  
FLUID TECHNOLOGY GROUP